

## Pyramid Stabiliser

<b>Component parts:</b>	1 x Car plate	1 x Quick release lever
	1 x Chassis Bracket	1 x Pack of fixing bolts
	1 x Clamp	1 x Stabiliser

### Fitting Instructions.

1. Remove the towball from the towbar assembly.
2. Bolt the car plate, (1), between the towball and the towbar using the bottom set of holes in the first instance.
3. Making sure you are on level ground hitch the car to the caravan, first making sure that the caravan hitch is at maximum extension and the brakes are off.
4. Fit the stabiliser, (2), to the car plate making sure the stabiliser is lying along the length of the caravan chassis. Place the 'U' shaped plastic bracket, (3), so that it's middle is 150mm from the end of the stabiliser blade and lift it until all the free play is taken up then lift it another 40-50mm until you feel some downward pressure. Make sure the blade can clear the bottom of the chassis and then clamp the bracket, (3), to the chassis.
5. If you have an Al-Ko or Taperline chassis you will need to use the 8x75mm bolts provided.
6. If you have a B&B type of chassis you will need the 8x25mm bolts. Make sure all drilled holes are on the chassis centreline and that there is clearance under the chassis. If there isn't then lower the car plate,(1), to the top set of holes and repeat steps 3 and 4.
7. **YOU MUST MAKE SURE THAT ALL BOLTS ARE FULLY TIGHTENED.**
8. You can adjust the amount of friction on the stabiliser by tightening the large nut underneath the quick release lever by a quarter to a half turn. If you do need to adjust it then you must make sure that the friction plates are kept parallel to each other. To do this you need to adjust the bolt, (4) and the recommended settings are a minimum pressure of 60lbs and a maximum of 80. **PLEASE NOTE THESE ARE NOT TORQUE SETTINGS.**
9. When in use the car plate toggle bolt, (5), should be no more than finger tight, plus a quarter turn.

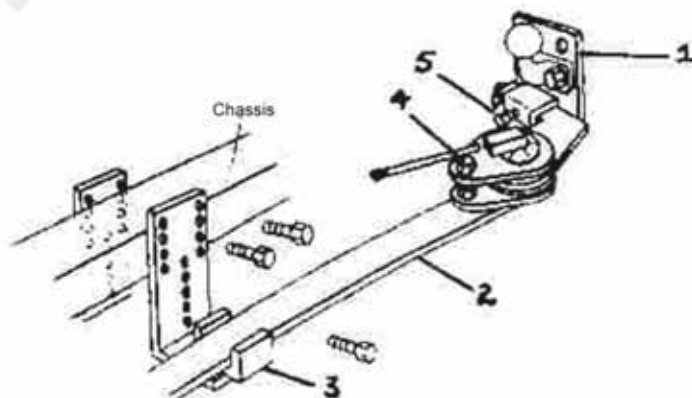

Copyright © 2000 -2007 'Thomson Caravans History & Information'

#### Disclaimer

The information provided on this Website site is offered with no warranty as to the authenticity, suitability or competence of the individual, company or service quoted here in. The Website shall not be liable for any damage or difficulty, direct or indirect, arising from utilisation of the information contained within these pages. Thomson T-Line History & Information is not responsible for the content of external websites.