

Breckland Trading company

Ranger PA10 Direct power Supply

Introduction

The New RANGER PA10 has been designed to provide a DIRECT Power Supply to the 12v services in a caravan or boat when fed from a 220/240v mains supply. Its torroidal transformer made to BS3535 has an output of about 120watts. The RANGER'S 12v output is sufficiently smoothed to enable it to operate fluorescent lights, water pump, and other 12v services efficiently. If a battery is installed, the RANGER will charge the battery at a variable rate depending on the power demand being required of the 12v system. It will not overcharge a battery in good condition. The RANGER will automatically reduce to a trickle charge, as the battery charges up.

Installation

The RANGER PA10 can be bolted down onto the floor or onto a bulkhead in the usual way. It wants some space leaving around the installation so that any heat can be dissipated from the RANGER. It stands to reason that the RANGER should not be inadvertently covered with clothing, sleeping bags, and similar items. The 240v mains lead should be connected to a protected mains supply, I.E. a consumer unit fitted with an RCD Mains Protection Device.

The 12v DC output should be connected as follows. Red to 12v positive, and Black to 12v negative. Connecting up to the correct polarity is vitally important.

Safety:

The RANGER PA10 is fitted with an 8amp (13 amp blow) fuse in the 12v output. *The correct fuse in the 12v output must be maintained at all times.*

Failure to use the correct fuse will invalidate the warranty on this product.

If unable to obtain the correct fuse contact Breckland Trading Co, at the address below.

Warranty

The RANGER PA10 is covered by a 12month warranty against faulty manufacture. In the event of any claim, the unit must be returned in the following condition. The mains and output leads must be essentially the same length as originally supplied. There must be proof that the correct fuse has been used at all times. Proof of the date and place of purchase must accompany any claim.

Breckland Trading Company Ltd

Fishley Lane,
South Walsham Road,
Acle,
Norwich,
Norfolk NR13 3ES

Tel: 01493 751620

Fax: 01493 754081

Email: sales@brecklandtrading.co.uk

Web: <http://www.brecklandtrading.co.uk>



Ranger Power Pack PA10

Breckland Trading company Ranger PA10 Direct power Supply

Caravan/Motorhome Wiring

IMPORTANT

FOR A MOTORHOME IGNORE 12S PLUG & SOCKET
(VIEW INTO SOCKET)

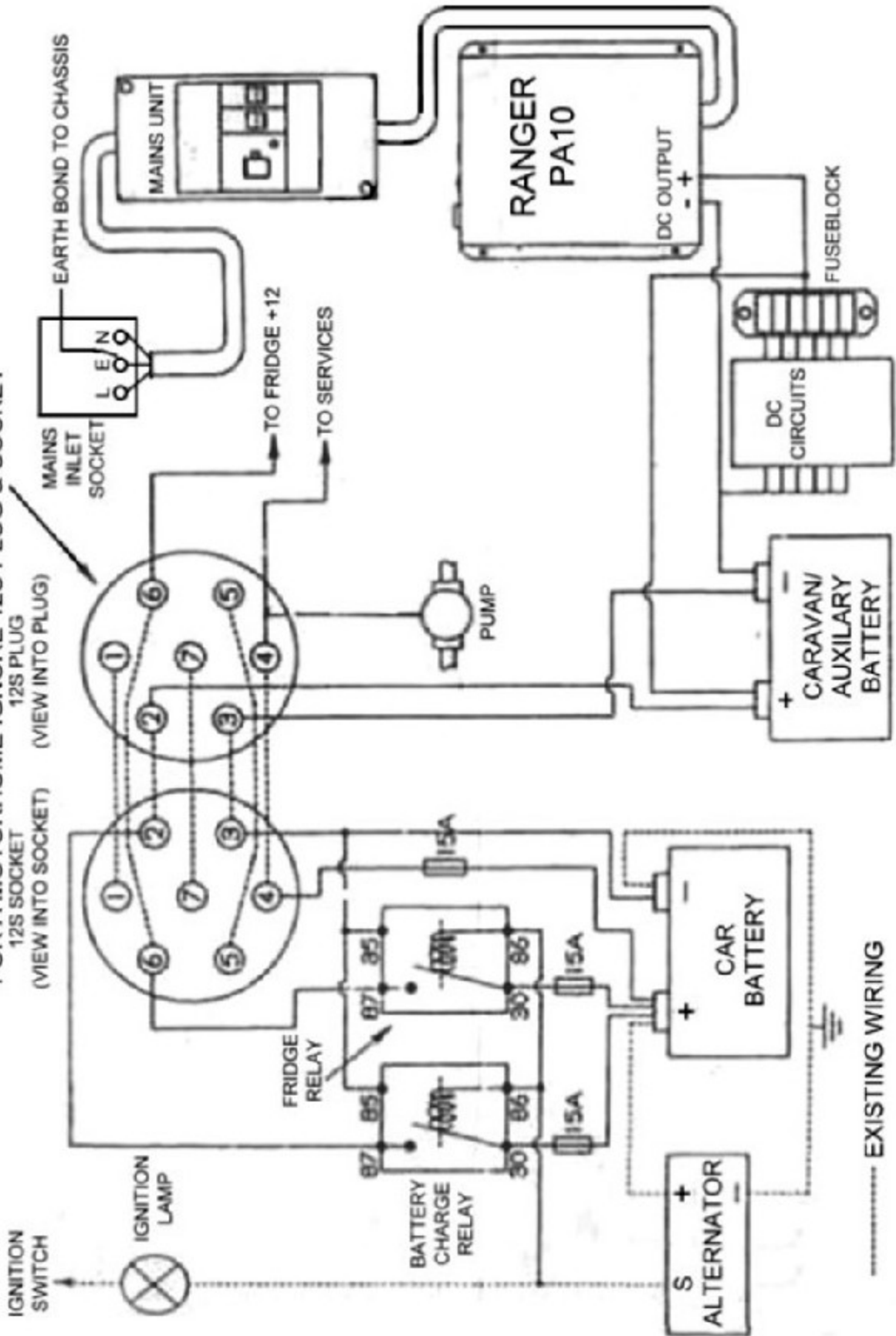

Car Wiring

----- EXISTING WIRING